



LANDSBERG

MOUNTING PROFILES



LANDSBERG

LANDSBERG was founded in 2001 in the northern Poland, near Gdańsk. From the very beginning of its existence it produced cold-formed sections.

It is 1000 different types of cold-bent profiles produced now - in thicknesses from 0.40 mm to 4.00 mm. As the second brand - STAHLBERG – it produces 10 types of roof and façade panels. Due to systematic development and innovative technologies, Landsberg is able to offer production of bespoke sections. The production process starts from cutting the coil sheets into strips before bending, and may be supported by additional services – milling, punching and welding.

In order to keep production capacity- there are many ironworks supplying Landsberg and over 600 customers are supplied by Landsberg all over the world. The company develops itself very fast, increasing a large number of satisfied customers. Quality standards are confirmed by ISO 9001:2015 certificate.

Our Company in numbers:

- 2 500 000 m of steel sections in stock at all times
- 55 000 m² - The total area of Company
- 13 000 m² of manufacturing and warehousing area
- 2 500 t of steel processed per month
- 1000 types of window reinforcements
- 10 types of roof and façade panels
- over 600 customers
- 110 motivated and experienced employees in R&D, QC, production, planning, logistics, design and sales departments
- 20 account managers and customer support specialists
- 25 production lines
- One of two largest window and door reinforcement producers in Poland

PRODUCTS:

- window and door reinforcements for all PVC window systems
- mounting rails, sections for ventilation, construction profiles, support channels, profiles for drywall systems, special welded profiles and others
- bespoke profiles with possible holes and process of milling, welding or punching
- only high-quality materials: galvanized steel for cold processing according to European quality and safety standards Steel (DX51D Z100-275)
- Thickness from 0.5 mm to 4 mm
- Standard profile lengths: 6 mt. At the Client's request from 0,25 to 6,5 m

QUALITY AND INNOVATION

Our Company manufactures and offers only high-quality products which conform to any European technical and safety standards.

Since 2009, LANDSBERG has been approved to ISO 9001 quality management system.

LANDSBERG has an excellent record of past growth which is likely to continue in the future and in 2015 was granted the "Diamonds of FORBES" award.

To ensure further development, the Company is planning to develop new innovative production technologies.

Mounting Profile STRUT STD

STD 41x21-22

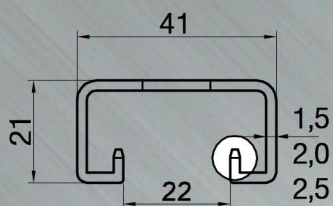

STD 41x41-22

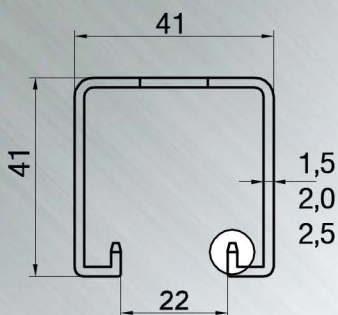

STD 41x62-22

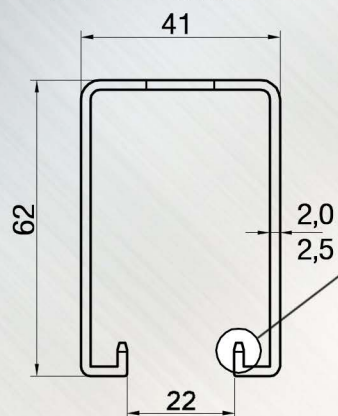

STD 41x82-22



Load capacity table for STD profiles

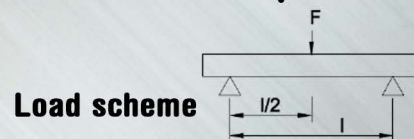

Profile	Weight [kg/m]	Moment of inertia		Strength factor		Weight limit F		
		I _x [cm ⁴]	I _y [cm ⁴]	W _x [cm ³]	W _y [cm ³]	Spacing 1m [kN]	Spacing 2m [kN]	Spacing 3m [kN]
STD 41x21/1,5	1,19	0,79	3,72	0,73	1,82	0,40	0,10	0,04
STD 41x21/2,0	1,45	0,96	4,67	0,89	2,28	0,49	0,12	0,05
STD 41x21/2,5	1,79	1,01	5,4	0,93	2,61	0,53	0,14	0,06
STD 41x41/1,5	1,66	4,47	6,21	2,13	3,01	1,36	0,55	0,24
STD 41x41/2,0	2,05	5,32	7,68	2,57	3,74	1,64	0,66	0,29
STD 41x41/2,5	2,56	6,24	9,28	2,95	4,48	1,83	0,77	0,35
STD 41x62/2,0	2,67	14,92	10,9	4,75	5,25	2,98	1,49	0,83
STD 41x62/2,5	3,33	18,02	13,19	5,74	6,69	3,60	1,80	1,00
STD 41x82/2,0	3,27	30,9	13,97	7,45	6,77	4,74	2,35	1,53
STD 41x82/2,5	4,1	37,33	16,90	9,01	8,19	5,73	2,85	1,86

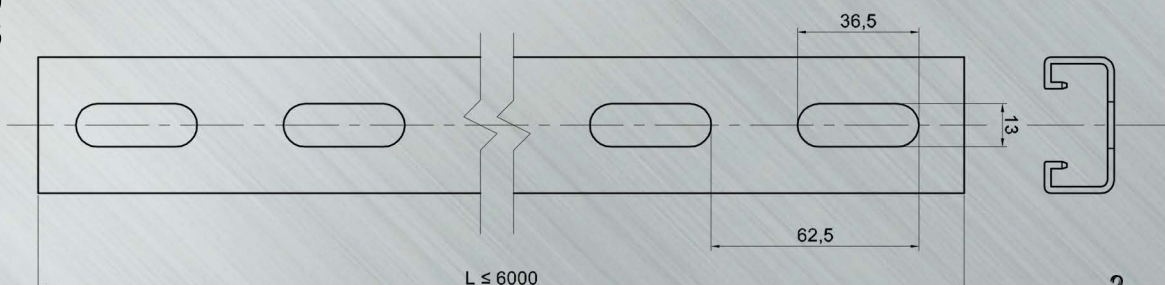

Mounting Profile STRUT STL

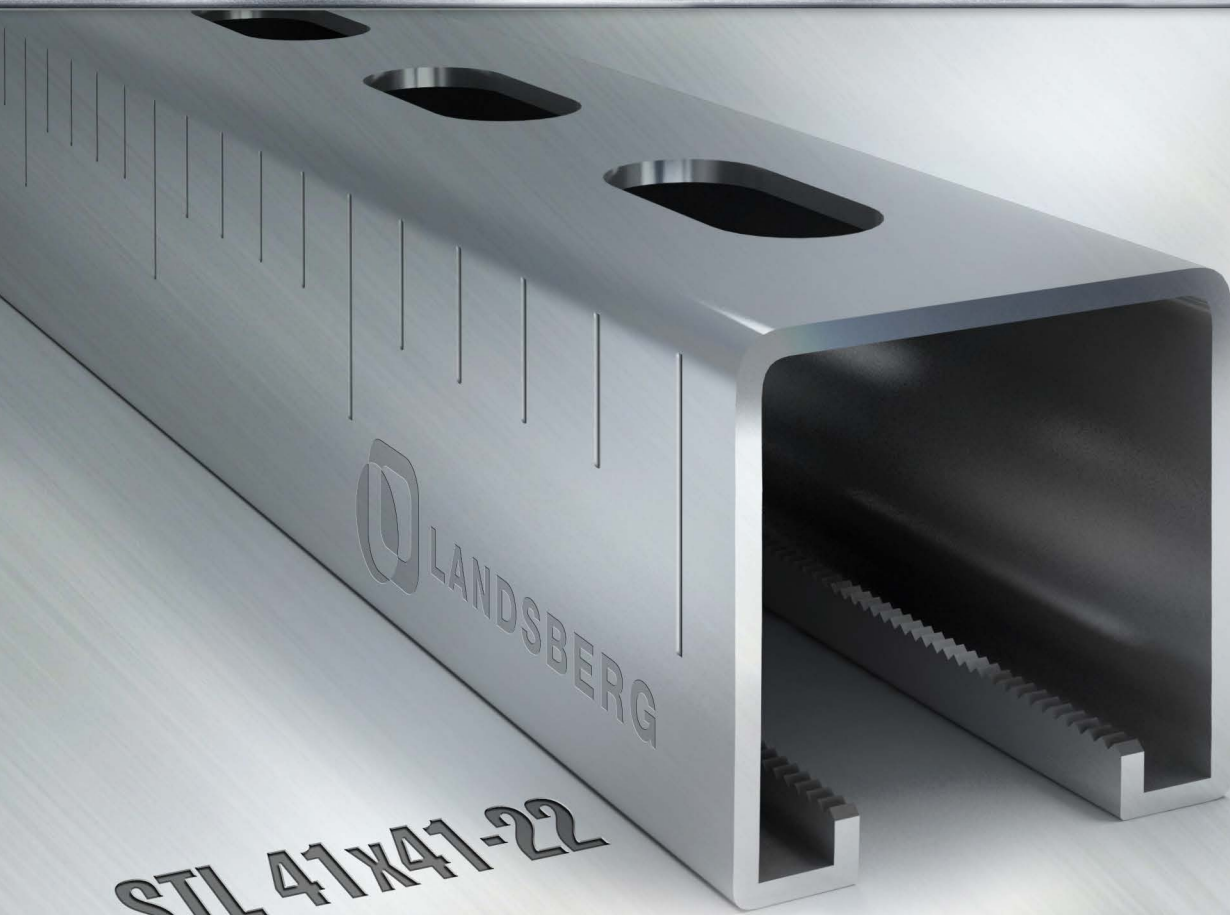

STL 41x41-22

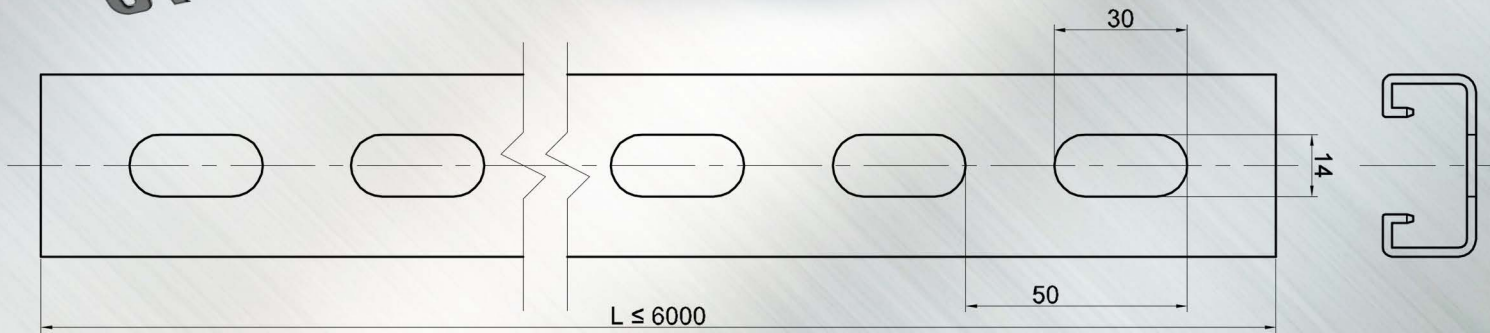

STL 41x21-22

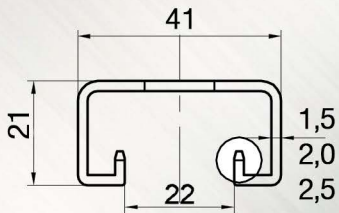

STL 41x62-22

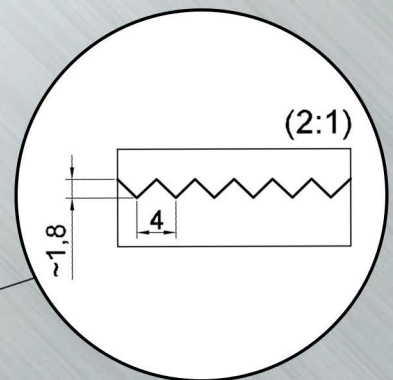
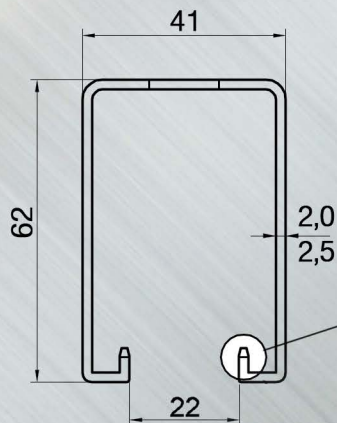

STL 41x41-22

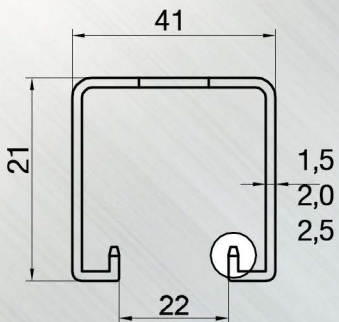

Mounting Profile STRUT MU

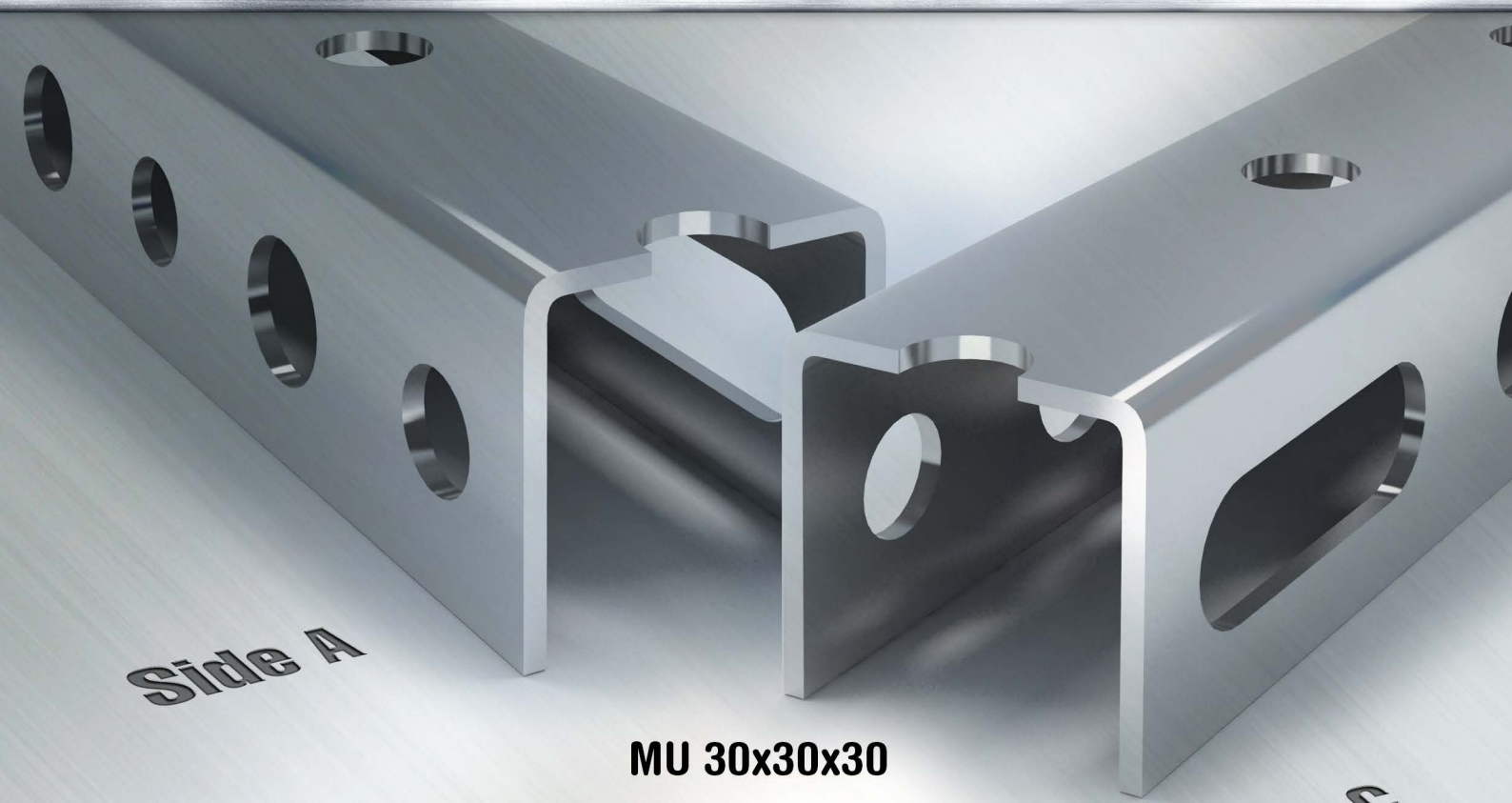

MU 30x30x30

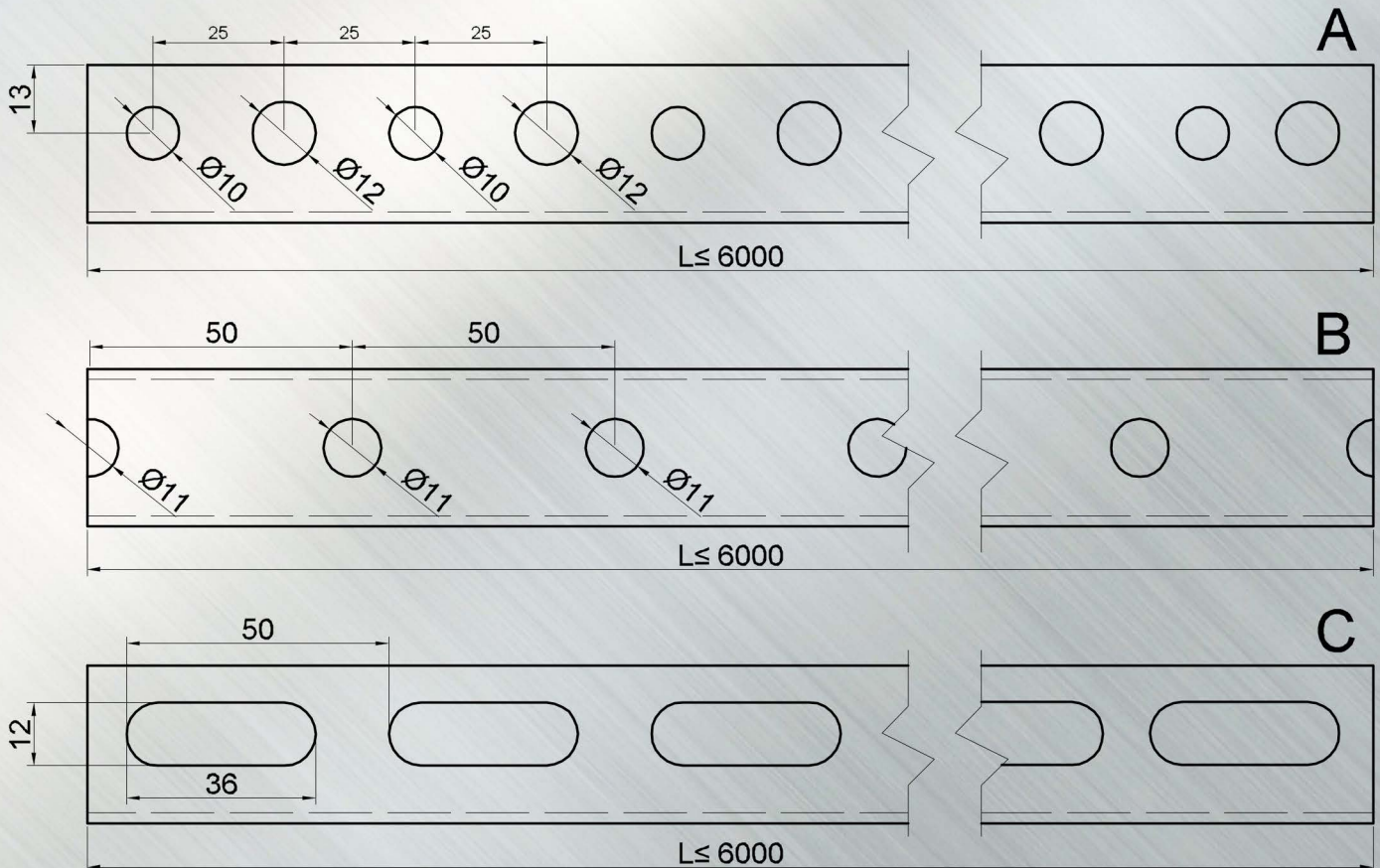
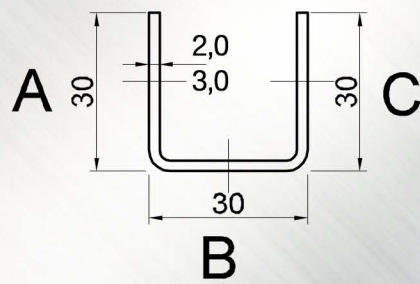

Mounting Profile ML



MC 30x30-15

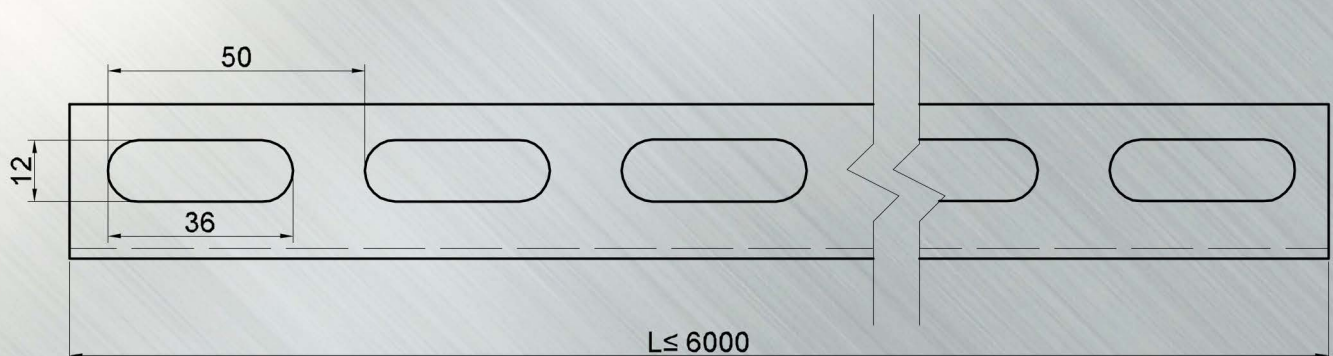
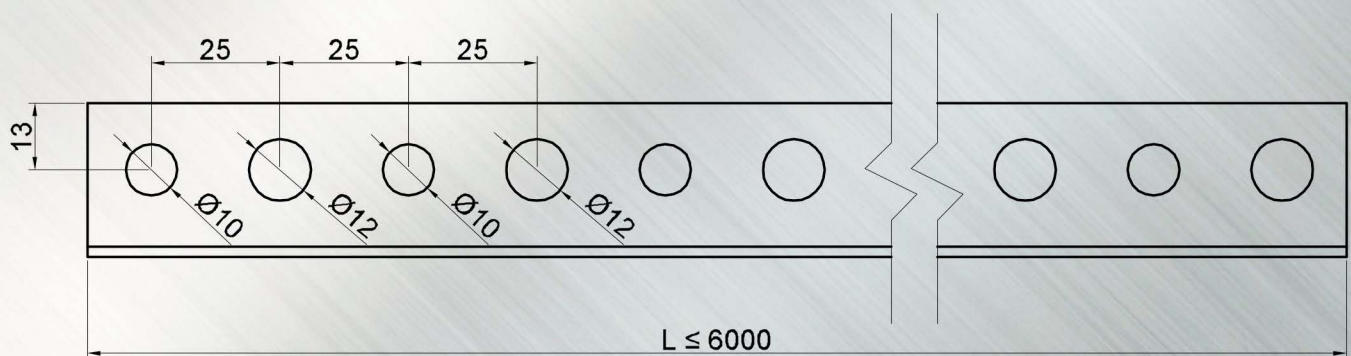
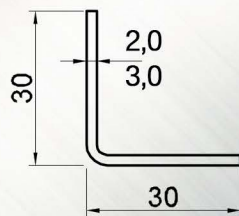

Mounting Profile MC

MC 27x18-15

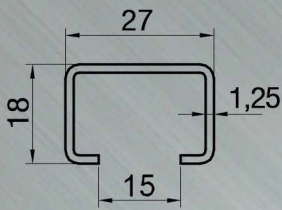

MC 28x30-15

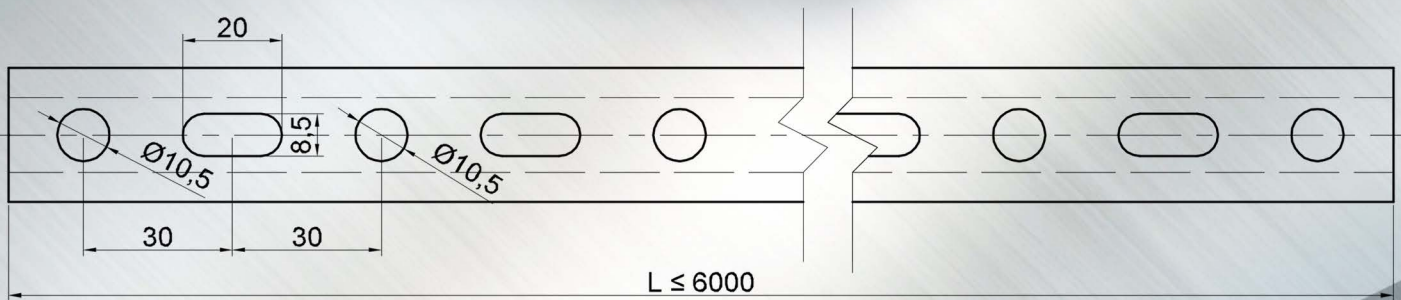
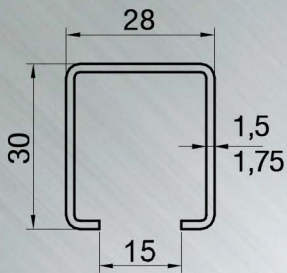

MC 30x15-15

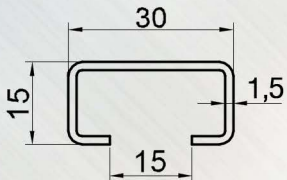

MC 30x20-15

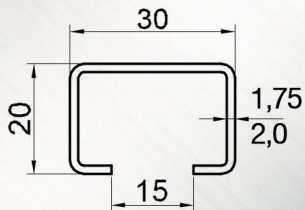

MC 30x30-15

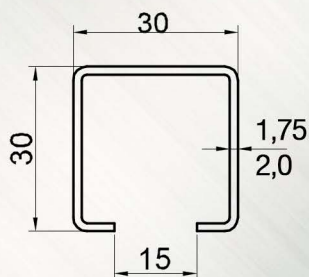

MC 30x45-15

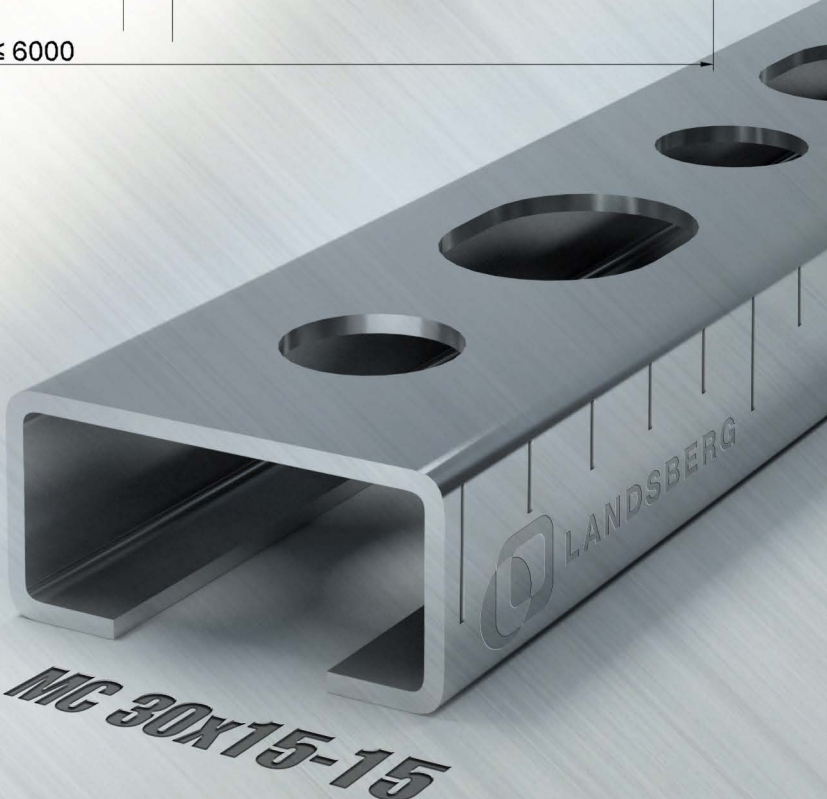
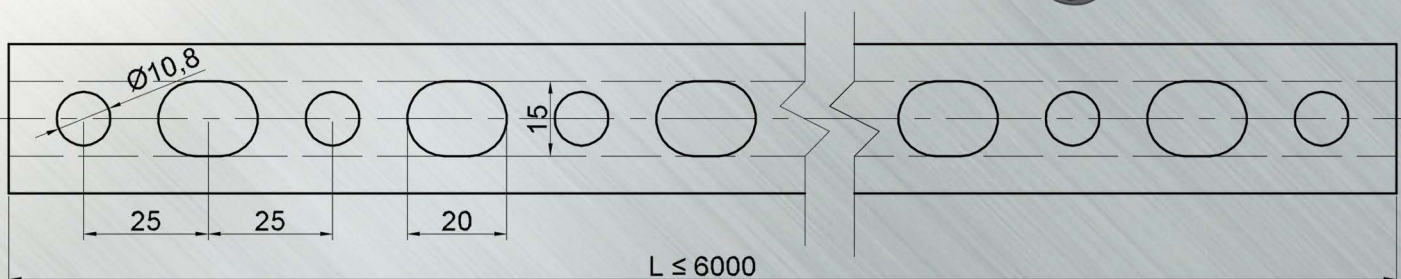
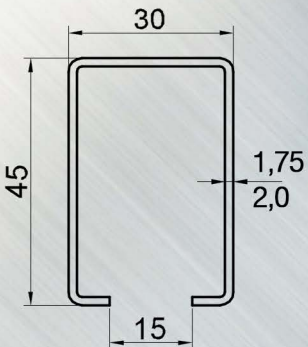

Mounting Profile MC

MC 38x40-17

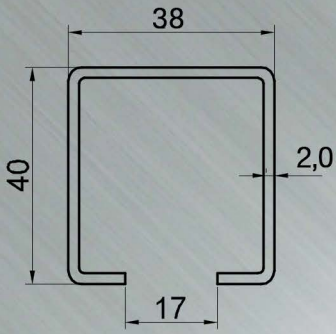

MC 40x60-17

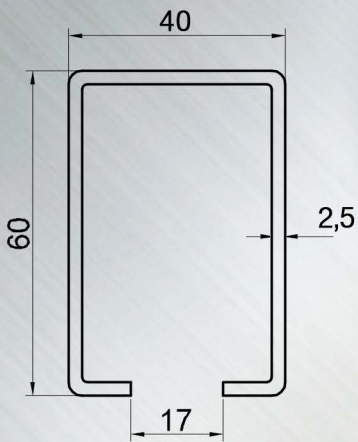

MC 40x20-22

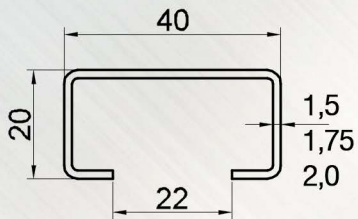

MC 40x40-22

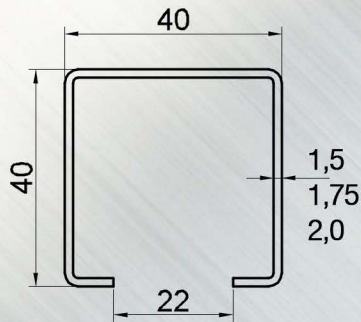

MC 40x60-22

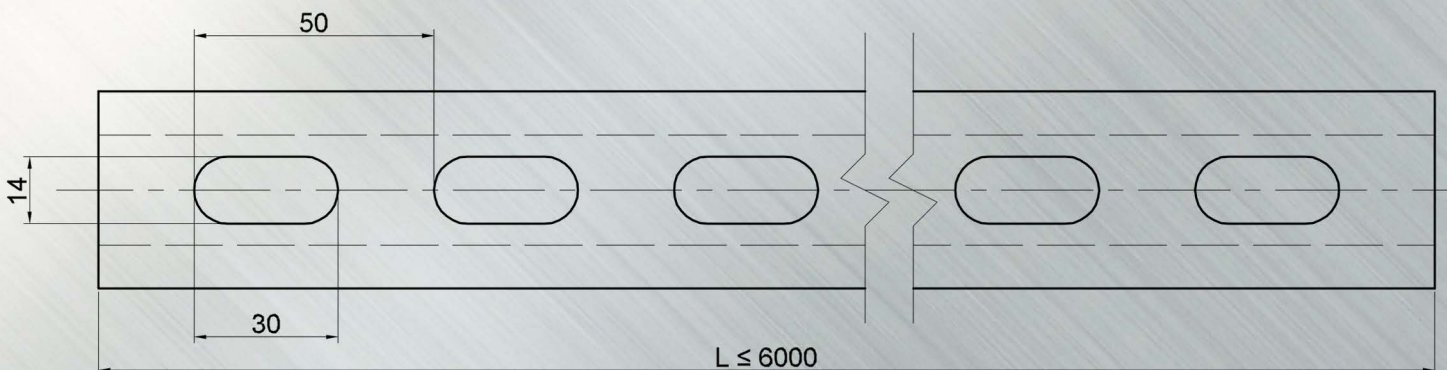
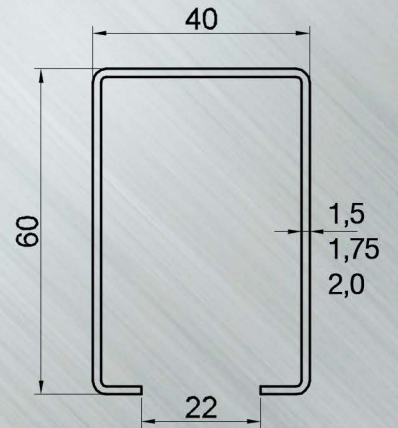

Unpunched and unperforated profiles

STD 41x62-22

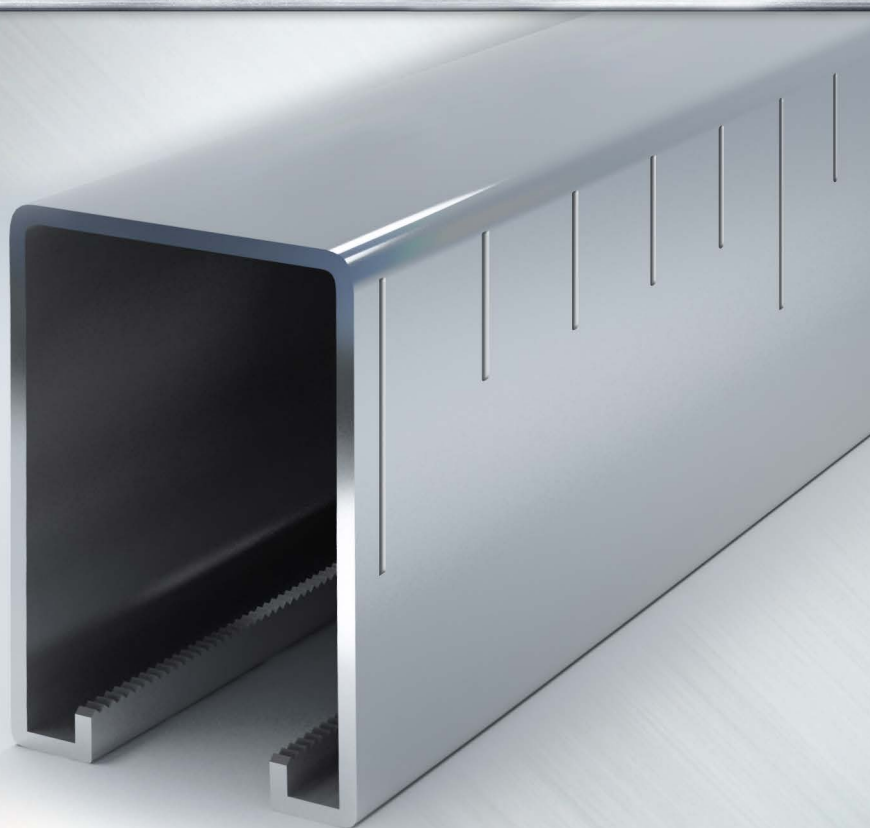
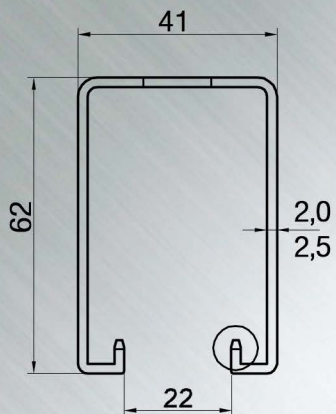

MC 30x15-15

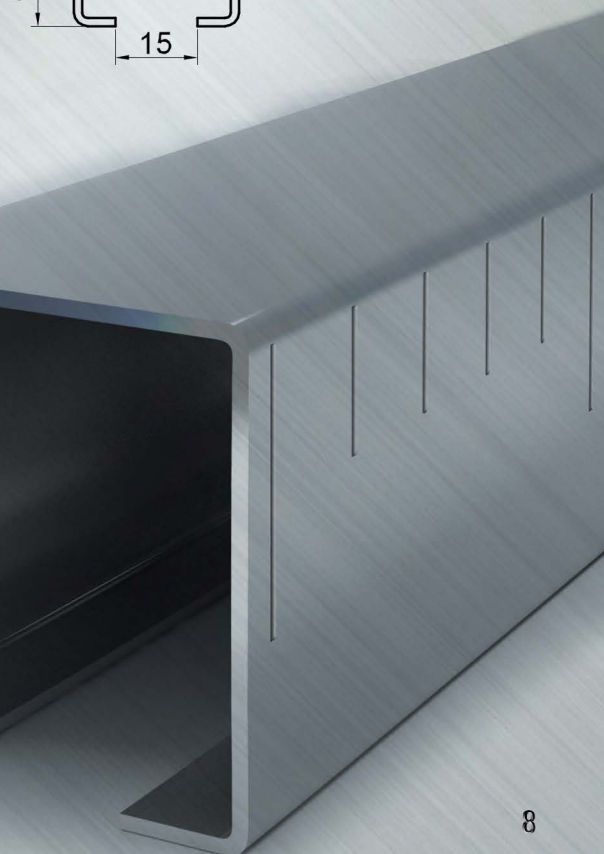
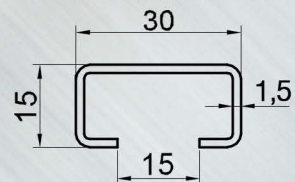

MC 40x40-22

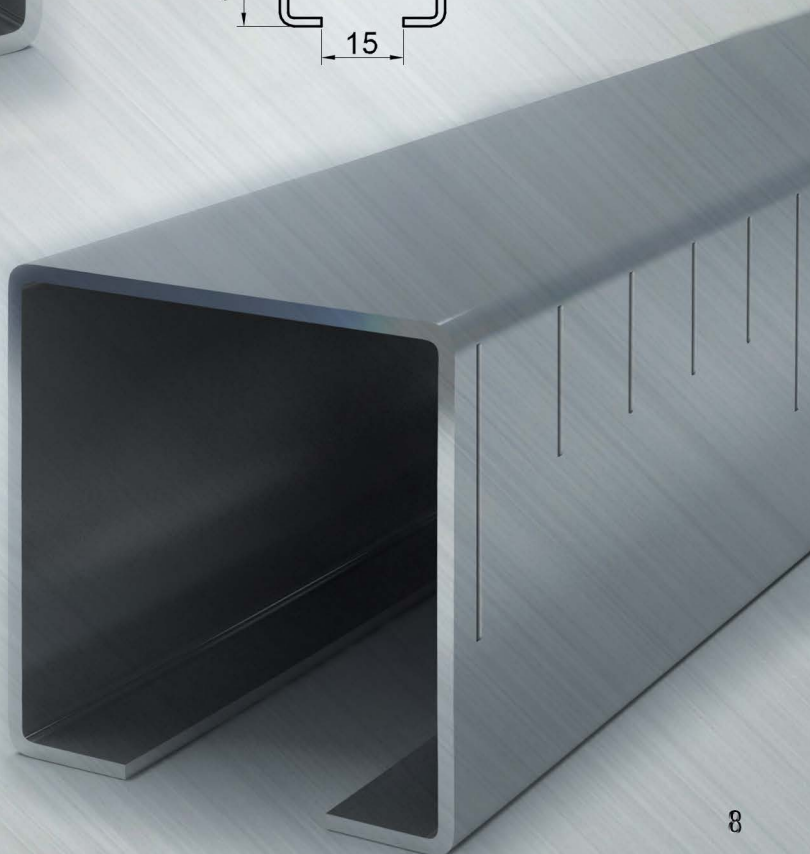
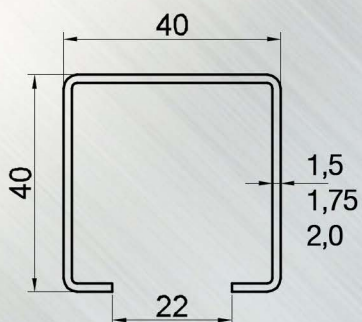

Unpunched and unperforated profiles **STD**



PROFILE	DIMENSIONS / mm	THICKNESS / mm
	41x21-22	1,5 / 2,0 / 2,5
	41x41-22	1,5 / 2,0 / 2,5
	41x62-22	2,0 / 2,5
	41x82-22	2,0 / 2,5

Unpunched and unperforated profiles

MC

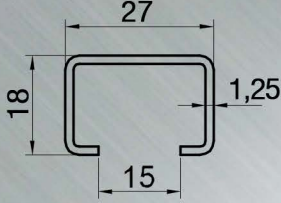
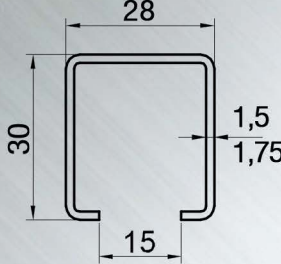
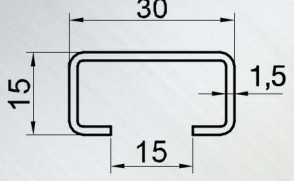
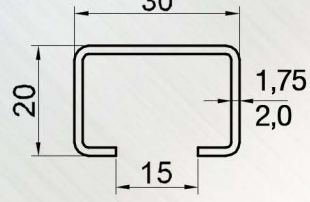
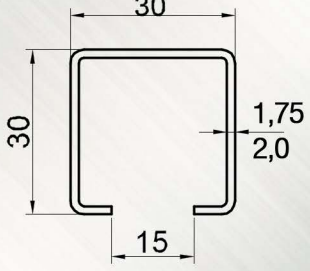
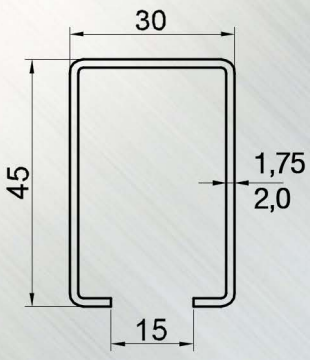
PROFILE	DIMENSIONS / mm	THICKNESS / mm
	27x18-15	1,25
	28x30-15	1,5 / 1,75
	30x15-15	1,5
	30x20-15	1,75 / 2,0
	30x30-15	1,75 / 2,0
	30x45-15	1,75 / 2,0

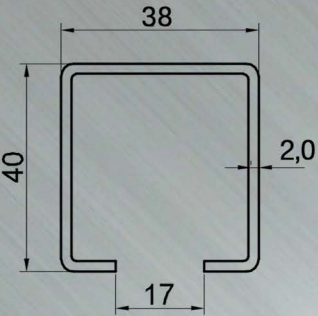
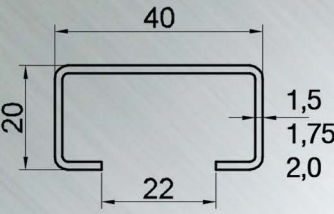
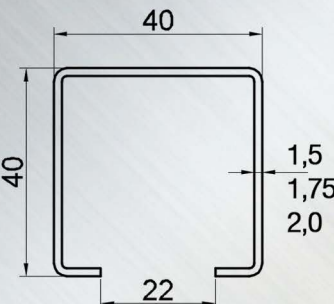
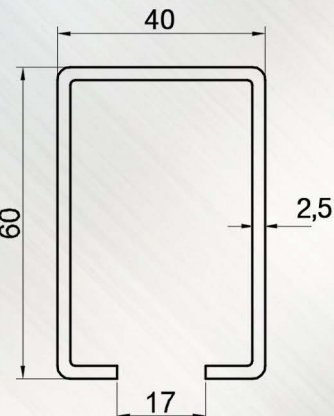
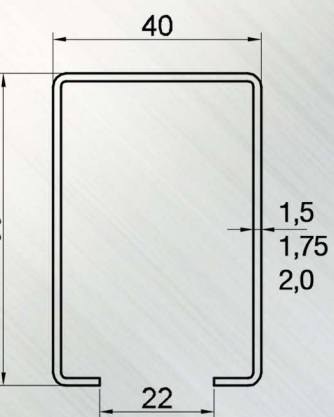
PROFILE	DIMENSIONS / mm	THICKNESS / mm
	38x40-17	2,0
	40x20-22	1,5 / 1,75 / 2,0
	40x40-22	1,5 / 1,75 / 2,0
	40x60-17	2,5
	40x60-22	1,5 / 1,75 / 2,0

VENTILATION SECTIONS

No.	Symbol	Dimensions (mm)	Thickness (mm)
1	S20	20	0,6
2	S30	30	0,7

S20

Thickness: 0,6 mm

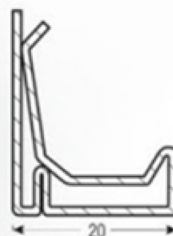

S30

Thickness: 0,7 mm

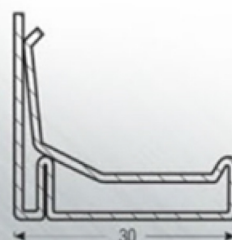

Example of packing

(5 x 5) x 2

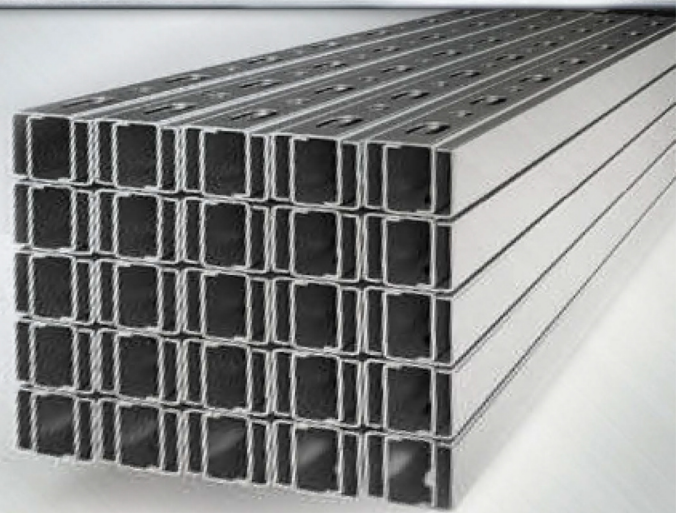
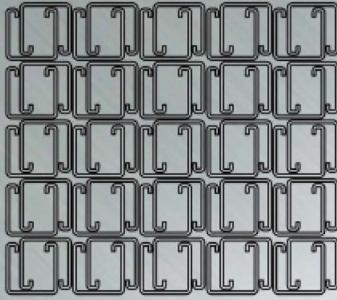

Channels manufactured by **Landsberg** are package in bundles (packages).

Materials used for packaging:

- Square timber.
- Plastic or steel tapes, black or lacquered according.
- Euro-pallets.
- Other packaging materials specified by customer.



Certificates





LANDSBERG Sp. z o.o. Sp. k., Wolental 15 i, 83-213 Skórcz, POLAND

Office: 0048 58 582 51 41
biuro@landsberg.pl